

TECHNICAL DATA SHEET

Document No:	P13-ÜT90
Issue Date	15.11.2012
Revision No	00
Revision Date	00
Page No:	1/1

(V66) 1000 CC OVAL HINGED CONTAINER

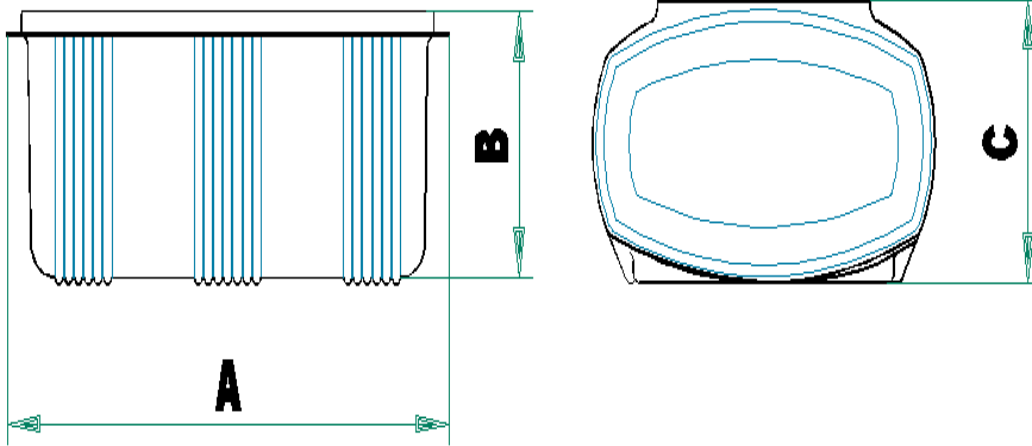

Dimensions	A (mm)	B (mm)	C (mm)
	125	85	177

WEIGHT

MIN	MAX
22,80	24,00

PRODUCT INFORMATION

Piece /Kg / Time	Product Weight $\pm\%2,5$ (g)	Gross Box Weight $\pm\%2,5$ (Kg)	Quantity per Boc (Pcs)	Minutes for 1000 pcs	Pcs / 1000 kg	Sheet (kg) for 1000 pcs
	23,4	10,56	400	6,94	28328,61	35,3

Production Details	Box per Hour (pcs)	Product per Hour (pcs)	Ullage Factor	Tool Cavity (pcs)	Production Rate (cycle / minute)	Sheet Dimensions
	21,60	8640	11,9	4	36	0,35 x 680

Knife, Box and Sleeve Bag	Knife Ref	Length of Knife (m)	Box Ref	Inner Box Dimensions L x W x H (mm)	Sleeve Bag Dimensions (mm)
	L11020160	4,1	103	580 x 397 x 550	50 x 80

PREPARED BY

TEAM LEADER

APPROVED BY

GENERAL MANAGER